



PO Box 220, Asquith SK S0K 0J0  
PH: (306) 329-4884 Toll Free: (866) 722-6246 FAX: (306) 329-4886  
Email: [quotes@frpmocoat.com](mailto:quotes@frpmocoat.com) Website: [www.frpmfg.com](http://www.frpmfg.com)

## **BALL TANKS**



**Underground Installation Instructions  
Anchor Kit Assembly and Warranty Information**

# TABLE OF CONTENTS

<b>1.</b>	<b>Limited Warranty .....</b>	<b>3</b>
<b>2.</b>	<b>Warranty Registration Form.....</b>	<b>4</b>
<b>2.</b>	<b>Introduction .....</b>	<b>5</b>
	• Owner Responsibilities	
<b>3.</b>	<b>General .....</b>	<b>5</b>
<b>4.</b>	<b>Handling .....</b>	<b>5-6</b>
	• Tank Inspection	
	• Unloading of Tank	
	• Storing Tank	
<b>5.</b>	<b>Excavation Parameters .....</b>	<b>6-7</b>
	• Stable Soil Conditions	
	• Unstable Soil Conditions	
<b>6.</b>	<b>Placing Tank in Hole.....</b>	<b>7</b>
<b>7.</b>	<b>Bed and Backfill Material .....</b>	<b>7</b>
	• Approved Backfill Material	
<b>8.</b>	<b>Cover .....</b>	<b>7</b>
<b>9.</b>	<b>Installation - Dry Hole .....</b>	<b>9-10</b>
<b>10.</b>	<b>Installation – Wet Hole .....</b>	<b>10-11</b>
<b>11.</b>	<b>Installation – Freezing Weather .....</b>	<b>11</b>
<b>12.</b>	<b>Anchoring .....</b>	<b>11-13</b>
	• General	
	• Use of Deadmen	
	• Use of Anchor Pad	
	• Hold Downs	
	• Tie-Down Kit Content	



## *LIMITED WARRANTY*

**Manufacturer's Warranty applies only to products manufactured by FRP Mocoat.**

FRP/Mocoat Fiberglass Ltd (FRP) fibreglass tanks are warranted against defects in material and workmanship and will perform according to our specifications provided that assembly and installation has proved satisfactory to FRP or agents.

Should any part (or parts) prove defective within five (5) years from the date of purchase, (proof of purchase required) it will be replaced or repaired by FRP without charge. Permission must be obtained from the factory prior to any warranty work being done.

Transportation to and from a dealer or factory will be at the owner's expense.

No allowance will be made for labour or other charges in replacement of defective parts.

Consequential damages, if any, are specifically excluded from this warranty.

### **What is not covered?**

This warranty does not cover:

1. A product which has been repaired or altered without written authorization from the manufacturer or authorized Dealer or Distributor as to affect its use or operation.
2. Equipment or accessories, which are not manufactured by FRP, whether or not warranted by other manufacturers.
3. Leakage from customer tanks that have been improperly assembled or improperly installed.
4. Product that has been abused, mishandled, accidentally damaged or operated contrary to printed instructions provided.
5. Loss of time, inconvenience, travel expense or other matters not covered hereunder.
6. Excavation, landscaping, or other installation/removal costs.
7. Products not paid in full per terms of sale.
8. Any act of God.

No oral or written information or advice given by Dealers, representatives, agents, or employees shall create a warranty or in any way increase the scope of this warranty. The manufacturer does not authorize any person to extend the time of this warranty or to create or assume for it any other obligation or liability with respect to its products. No person, including Dealers and Distributors is authorized to make repairs or replacements under this warranty without the prior written approval from the Manufacturer. This warranty is not transferable or assignable.

THE MANUFACTURER SHALL NOT BE LIABLE FOR CONSEQUENTIAL, SPECIAL OR INCIDENTAL DAMAGE RESULTING FROM A BREACH OF THE EXPRESSED OR IMPLIED WARRANTY WHICH IS NOT DISCLAIMED HEREIN NOR ANY OTHER LOSS OR DAMAGE, EXCEPT AS SET FORTH ABOVE.

### **CONTACT INFORMATION FOR ANY WARRANTY INQUIRIES:**

**PHONE: (866) 722-6246 or (306) 329-4884**

**FAX: (306) 329-4886**

**EMAIL: [quotes@frpmocoat.com](mailto:quotes@frpmocoat.com)**



**Return Form  
To Factory**

### WARRANTY REGISTRATION FORM

This form must be completed at the time of installation and returned to FRP/Mocoat Fiberglass Ltd for warranty approved and validation within ten (10) days of burial.

Customer Name: \_\_\_\_\_ Phone No.: \_\_\_\_\_

Address: \_\_\_\_\_  
STREET ADDRESS/BOX NO. CITY STATE/PROV

Tank Site Location: \_\_\_\_\_ Site Phone No.: \_\_\_\_\_

Tank Model No.: \_\_\_\_\_ Tank Invoice No.: \_\_\_\_\_

Contractor/Installer: \_\_\_\_\_ Phone No.: \_\_\_\_\_

Address: \_\_\_\_\_  
STREET ADDRESS/BOX NO. CITY STATE/PROV

#### 1. PREINSTALLATION

**Completed By**

- Read Burial Instructions On Tank \_\_\_\_\_
- Water Test: Dig a hole one foot in depth for entire length of tank to stabilize the tank. Fill tank entirely with water, just above the collar to test for any leak. Test tank for at least one (1) hour. Water testing applies only to sectional tanks assembled by customers. One piece tanks are leak tested at the factory. \_\_\_\_\_
- Visual Inspection: No evidence of physical damage to tank (check for holes, cracks, etc.). If any physical damage is found do not install tank! Contact FRP/Mocoat Fiberglass Ltd. \_\_\_\_\_
- Backfill Material: Backfilling must be pea gravel or crushed stone. Any other type of backfill must be pre-approved by FRP/Mocoat Fiberglass Ltd. Failure to use specified backfill will void Warranty. \_\_\_\_\_
- Excavation: Hole dimensions meet requirements from installation instructions. \_\_\_\_\_
- Hole Condition: Indicate condition of hole: \_\_\_\_\_
  - Dry Hole: Water is not anticipated to reach tank. Area is not subject to flooding. \_\_\_\_\_
  - Wet Hole: Excavation may trap water. Area is subject to flooding. \_\_\_\_\_
  - (If wet hole, please see special wet hole instructions)

#### 2. DURING INSTALLATION

**Completed By**

- Backfill material bed must be minimum of 12" \_\_\_\_\_
- Inspect tank for physical damage after setting into hole \_\_\_\_\_
- Backfill layers pushed and probed under tank and between ribs to eliminate all voids \_\_\_\_\_
- Tank is properly ballasted during installations (Wet-hole installation only) \_\_\_\_\_
- Indicate final backfill depth over tank. \_\_\_\_\_
- Piping connections are flexible connections where required. \_\_\_\_\_

I CERTIFY THE INSTALLATION OF THE ABOVE TANK AT THE ABOVE LOCATION TO MEET ALL INSTALLATION REQUIREMENTS OF FRP/MOCOAT FIBERGLASS INC AND ALL INFORMATION IN THIS INSTALLATION FORM IS TRUE.

Signature of Owner: \_\_\_\_\_ Date: \_\_\_\_\_

Signature of Installer/Contractor: \_\_\_\_\_ Date: \_\_\_\_\_

**CONTACT FRP/MOCOAT FIBERGLASS LTD FOR ANY TECHNICAL INQUIRIES**  
PHONE: (866) 722-6246 or (306) 329-4884 FAX: (306) 329-4886  
EMAIL: [quotes@frpmocoat.com](mailto:quotes@frpmocoat.com)

## 1. INTRODUCTION

- It is the responsibility of the owner, installer, and the operator to follow all requirements contained in this Installation Manual. In addition, they must comply with all Local, Provincial/State and Federal safety regulations that may apply to tank installations and operations.
- Instructions or procedures in the Installation Manual should not be interpreted to place any person's health or safety at risk. Working in and around excavations can be dangerous!

## 2. GENERAL

- Follow the directions provided by this Manual for safe and proper installation of fibreglass underground tanks. Failure to follow these instructions will *void* the tank warranty and may cause tank failure.
- Local Provincial/State and Federal Codes/Regulations always take precedence over FRP/Mocoat Fiberglass Ltd requirements/recommendations.
- It is necessary to retain all correspondence regarding variations to installation requirements for a valid warranty claim. Pictures are required.
- Your tank Warranty Registration Form must be completed and returned to FRP/Mocoat Fiberglass Ltd within the time specified. Retain a copy of the completed form for your records. (See Appendix).
- All product returns must have an RMA (Return Material Authorization) as approval from FRP/Mocoat Fiberglass Ltd. Returned goods must be delivered or shipped prepaid and will be subject to a 25 percent restocking fee. Special made-to-

order fibreglass products and/or components are non-refundable.

- **If inlet is equipped with 4" butyl grommet, these instructions must be followed:**
  - **Grind down the outside edge of the incoming pipe (chamfer).**
  - **Apply pipe lubricant to the pipe and grommet.**
  - **Place pipe through grommet with 3"-4" of pipe extending into tank.**
  - **Glue supplied 4" PVC-DWV elbow onto pipe with the elbow pointing towards bottom of tank.**
  - **Glue 4" PVC Pipe x 6"L (if supplied) onto bottom of elbow.**

## 3. HANDLING

### Tank Inspection

- Before the Ball Tank is unloaded, visually inspect the entire exterior surface of the tank to ensure that shipping or handling damage has not occurred. You may then sign the shipping document to accept the tank as delivered. However, if you discover damage to the tank, do not attempt repairs. Instead, contact your Factory Sales Representative.

### Unloading of Tank

- *Warning* – Do not release the ratchet straps securing the Ball Tank to the truck or flat bed trailer, etc. until the lifting equipment is secured to the tank's lifting lug(s). Failure to do so could result in death or serious injury.
- Lift the tank by using the lifting lugs only. Use a spreader bar for lifting a tank that has two or more lifting lugs. Use a lifting cable instead of a spreader bar if the angle between the cable and the tank top exceeds 60 degrees.
- *Do not* drop, impact, or roll the Ball Tank. Handle the tank with care.

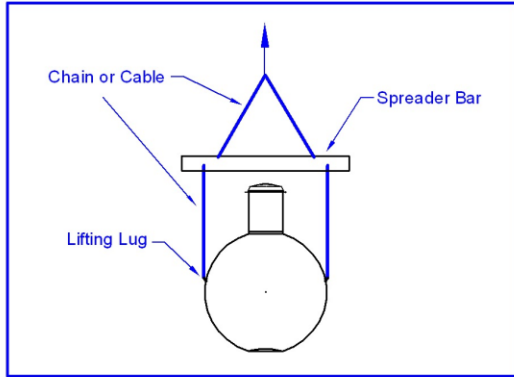

FIGURE 3-1

- Some Ball Tanks may be rotated on the truck for shipping purposes. They may have extra lifting lug(s) to aid in the loading and unloading process. When the tank is rotated and has extra lifting lugs, use all the lifting lugs that are located on top of the tank in its rotated position to unload the tank. (To install the tank use all the lifting lugs that are located on top of the tank in its upright position.)

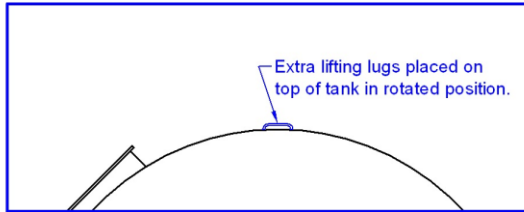

FIGURE 3-2

- Be sure to use equipment that is rated to handle the load.

### Storing Tank

- Select a solid, level area to place the tank. Make sure the area is clear of rocks and debris.
- Anchor the tank at each end with a rope to prevent it from rolling away.

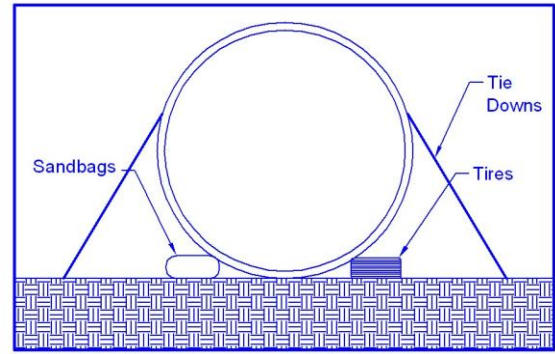

FIGURE 3-3

## 4. EXCAVATION PARAMETERS

- A standard Ball Tank is designed to have a maximum burial depth of ten (10) feet of cover over top of the tank. Call FRP/Mocoat Fiberglass Ltd for a special quotation for a made-to-order Heavy Duty (H/D) Ball Tank if the burial depth is to be greater than ten (10) feet.
- The following are the minimum required Ball Tank spacings. The spacings must be increased as needed to accommodate deadmen or anchor slabs.

### Stable Soil Condition

- Holes must be large enough to allow for the minimum required distance between the Ball Tank at the flange (if 2-piece model), and the minimum required distance from the ends and side of the tank to the walls as specified in Provincial/State Legislation. *Under no circumstances should the distance between the tank and the hole walls be less than 12 inches.*



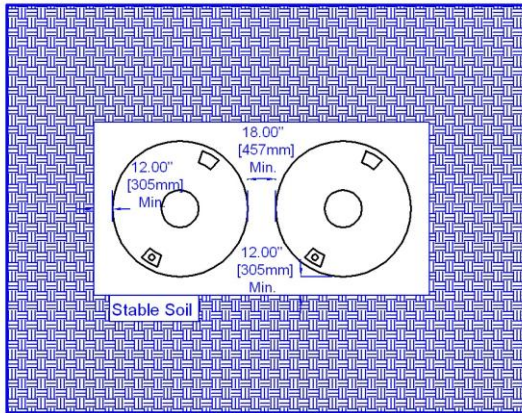

FIGURE 4-1

- If you are installing more than one Ball Tank in the same hole, at least 18 inches of backfill material is required between each tank.
- Determine the tank's hole depth from the tank ground cover requirements (plumbing needs).
- Under the Ball Tank(s), the bed thickness must be at least 12 inches thick over native soil or concrete slab. (24 inches when using rubber shred)

#### Unstable Soil Condition

- FRP/Mocoat Fiberglass Ltd recommends that the Ball Tank owner seek the advice of a local Professional Engineer with training in soils science if the soil is extremely soft, unstable, expansive clay, or quicksand, etc.

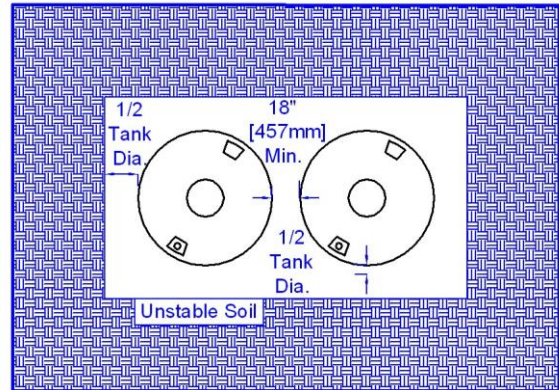

FIGURE 4-2

#### 5. PLACING TANK IN HOLE

- Carefully lower end of the Ball Tank into the excavation by using the lifting lugs and a spreader bar when necessary. (Under no circumstances should chains or wire slings be used around the tank.)
- Use guy ropes to guide the tank when necessary.
- *Do not* roll the tank to move it.
- Always take extra care when handling a tank with a bottom fitting or sump to prevent damage to the fitting.

#### 6. BED AND BACKFILL MATERIAL

##### Approved Backfill Material

- **Pea Gravel:** A natural, rounded aggregate, clean and free flowing, with particle size not less than 1/8 inch or more than 3/4 inch diameter.
- **Stone or Gravel Crushings:** Stone or gravel crushings, clean and free flowing with angular particle size not less than 1/8 inch or more than 1/2 inch diameter.
- **Rubber Shred:** Recycled rubber shred is an approved backfill material for the Ball Tank ONLY. Acceptable shred will be between 2" and 5". See next page on proper burial

**instructions when utilizing Rubber Shred.  
DO NOT USE RUBBER CRUMB.**

- **Rubber Shred:** Recycled rubber tire chips available through various rubber tire recycler

**Note:** Using other than approved bedding and backfill materials without prior written authorization from FRP/Mocoat Fiberglass Ltd will *void* the tank warranty.

- Use only specified backfill material throughout. The backfill material must not contain any foreign material, such as rocks, brick, clay, wood, native soil, etc.
- Sharp objects must not contact the Ball Tank at any time. Remove any supports used for the installation of piping prior to backfilling to grade.
- The object of backfill is to construct a uniform, homogenous envelope of firm, aggregate material around the Ball Tank.
- If the tank must be filled with liquid (Wet-hole installation) during the backfilling process, the level of the liquid inside the Ball Tank must not exceed the level of the surrounding backfill material by more than 24 inches.

## 7. COVER

### Minimum Cover – No Traffic

- Two (2) feet of backfill material is the minimum cover required if there will not be a vehicle load over the tank at any time.

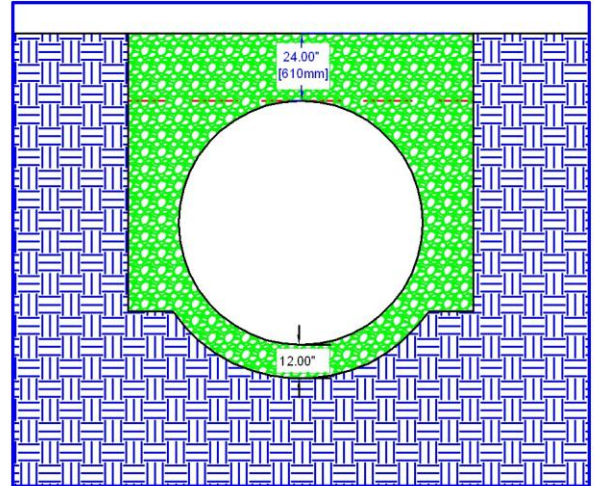

FIGURE 7-1

### \*\*Minimum Cover – Traffic Loads (Light)

- A Heavy Duty tank must be installed where it is subjected to light traffic loads and must have a ground cover of at least:
  - a. Five (5) feet of backfill material, or
  - b. Two (2) feet of backfill material on top of the tank including an unreinforced concrete surface pad at least eight (8) inches thick, or
  - c. Two feet of backfill on top of the tank including a reinforced concrete surface pad at least six (6) inches thick.

**Note:** Contact your Factory Representative if “heavy” traffic load situations occur.

- The concrete pad must extend horizontally at least 18” beyond the tank in all directions. Asphalt pavement is not a substitute for concrete pads.
- The concrete pad must be designed with a suitable rebar grid.
- Barricade the area to prevent traffic over the tank until the minimum ground cover requirements are completed.



\*\*This application is for special ordered H/D tanks.  
Contact FRP/Mocoat Fiberglass Ltd for additional charges.

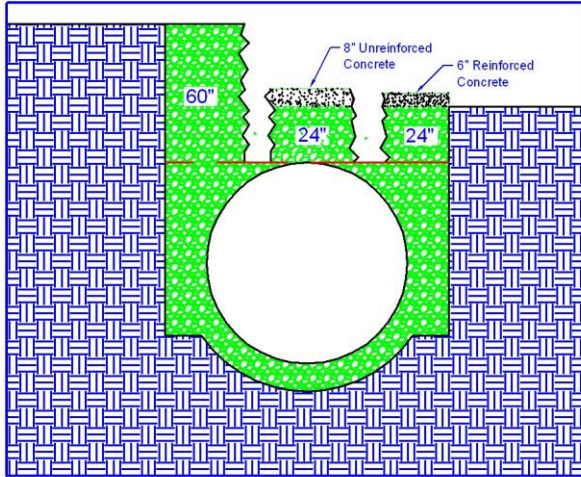

FIGURE 7-2

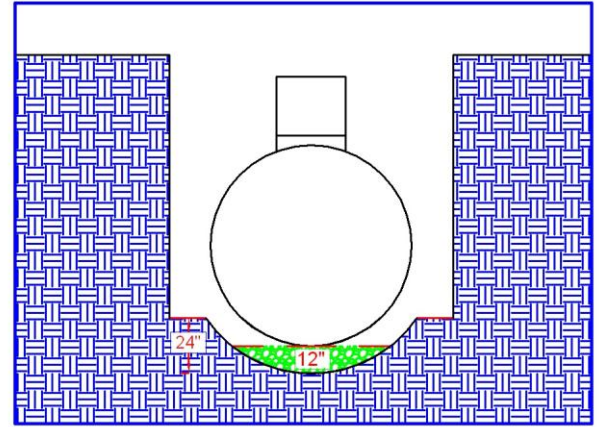

FIGURE 8-1

- *Do not* use timber, beams, or cradles to support the Ball Tank(s).

**Warning:** Use only specified backfill material for bedding.

## 8. INSTALLATION – Dry Hole

- Excavate the site to allow for an eighteen (18) inch space around the outside of the tank.

**Note:** A ten (10) foot burial tank must not have any more than ten (10) feet of specified backfill material measuring from the top of the tank to ground level.

### Backfill Bed

- Ensure the hole is deep enough to provide for a 12 inch minimum backfill be of approved backfill material over the holes bottom or concrete slab. **(24 inches for rubber shred)**
- *Do not* place the tank(s) directly on concrete slabs.

### Side/End of Tank

- Continue backfilling the Ball Tank with the same backfill material. Backfill in uniform layers no greater than 12 inches at a time.
- Ensure that all voids between, and under the Ball Tank(s) are completely filled.
- The quality of backfill material around the Ball Tank between the 4 and 8 o'clock positions (see illustration below) is critical to ensure quality tank performance.

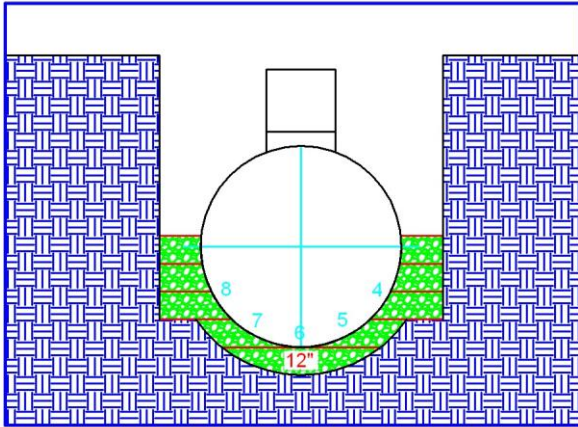

FIGURE 8-2

### Top of Tank

Continue backfilling with the same backfill material above the top of the tank in 12 inch lifts until ground requirements are met. **(If utilizing rubber shred, 24" of rubber shred is required above the top of the tank)**

**Warning:** Do not allow vehicle traffic or heavy loads to go across the tank; this will void the warranty!

Contact FRP/Mocoat Fiberglass Ltd for special order Ball Tanks that can accommodate traffic, extreme conditions or any other adverse situations to which the tank may be subjected.

### Rubber shred fill:

**FRP/Mocoat Fiberglass Ltd Ball tanks have been tested and approved to be backfilled with recycled rubber chips. Rubber shred is available through numerous vendors throughout the provinces. Acceptable size of shred is between 2" and 5".**

### Requirements for rubber shred backfill:

- Under the Ball Tank(s), the bed thickness must be at least 24 inches thick over native soil or concrete slab.
- Minimum 12 inches of shred must surround tank on all sides.

-Minimum 24" of rubber shred above the tank prior to utilizing native fill.

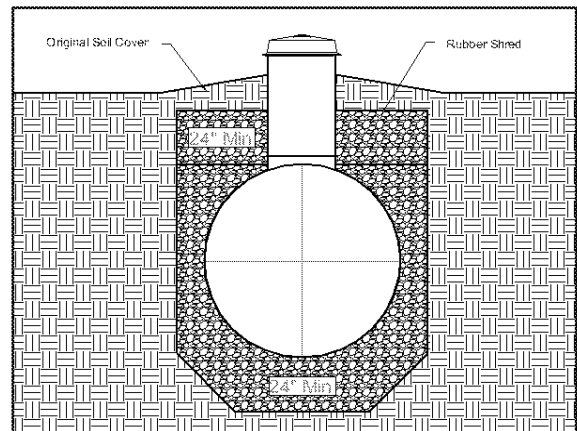

FIGURE 8-3A

## 9. INSTALLATION – Wet Hole

### Water Level, Pumping, Bed

- Excavate pumpout wells at the corners of excavation to *keep the water below the tank bottom.*
- Install a 12 inch bed of specified backfill material and position the tank on the bed.
- *If extremely difficult water conditions* at the site are suspected, such as underground streams, surface run-off locations, shorelines or wide fluctuations in water level, etc., increase the bed thickness to 18 inches and clearances between the tank and hole walls to a minimum of 18 inches.

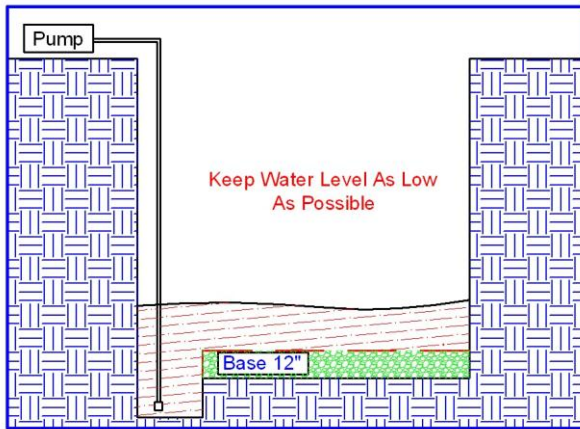

FIGURE 9-1

### Ballasting

- If the ground water level is expected to exceed the tank bottom level at any stage of the backfilling process, ballasting will be necessary until the tank is anchored and buried to grade.
- The tank must not float after commencement of the backfilling process.

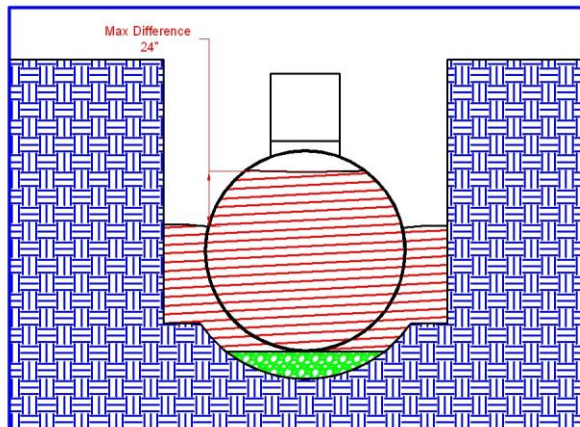

FIGURE 9-2

- The water ballasting level in the tank must not be higher than 24 inches above the water level in the hole.
- A lifting cable may be used to guide the Ball Tank during the sinking process but it must

not become tightened to excessively load the lugs.

### Backfilling

- Make sure that the minimum required clearances are maintained before starting to backfill. See Section 4.
- Proceed with the backfilling processes as per the dry hole installations instructions mentioned earlier using only specified backfill material.
- To prevent the tank from floating during spring thaw or high water table condition, leave the tank approximately 1/3 full over the winter months. This weight will keep the tank in place. Freezing of sewage or water when the tank is 1/3 full will not affect the tank since ice will have room to expand beyond the 1/3 level. Do not allow liquid to freeze beyond the 1/3 full level!

## 10. INSTALLATION – Freezing Weather

- To ensure the bed is not frozen under the tank, the aggregate must be free flowing without the use of calcium chloride. Under such conditions, the backfilling process should be completed within one working day.
- Backfill material that has frozen into lumps must be completely thawed first, before being used as backfill. (**Caution:** Steaming may cause subsequent refreezing of fill material).
- The bottom of the excavation must also be free of frost and the walls of the excavation free of snow and ice.



## 11. ANCHORING

### General

- **The decision whether or not to anchor the tank and the selection of the anchoring method is the sole responsibility of the owner.**
- Consider using concrete deadmen or pads if there is a problem with extreme water levels when installing the tank.
- Anchoring the tank down will help prevent any chance of the tank floating due to the hydraulic effect of ground water when it is empty.
- For severe water conditions or ground movement, a heavy duty (H/D) Ball Tank must be installed to handle the increase in ground water pressure. In addition, the tank must remain at least 1/3 full *at all times*.
- Anchoring shall be engineered based upon tank size, ground cover, water table elevation and calculated uplift force on the empty tank.

### Use of Deadmen

- Deadmen are typically reinforced concrete beams. You may purchase deadmen if each section contains at least two balance points.
- Lay the deadmen in the excavation parallel to the tank and outside of the tank “shadow”.
- Install the bottom of the concrete deadmen at the same elevation as the bottom of the tank.
- The Ball Tank and the deadmen should not come in contact with each other. Instead, provide sufficient clearance to allow the

deadmen to be set outside the tank “shadow”.

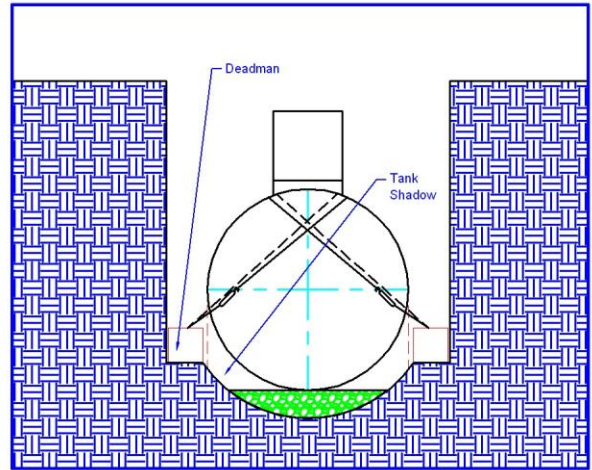

FIGURE 11-1

### Use of Anchor Pad

- An anchor pad is typically a reinforced concrete base.
- The total length of the slab must extend at least 18 inches beyond the tank in all directions.
- The thickness of the reinforced slab should be at least eight (8) inches thick.
- Provide a separate anchor point for each hold down cable.

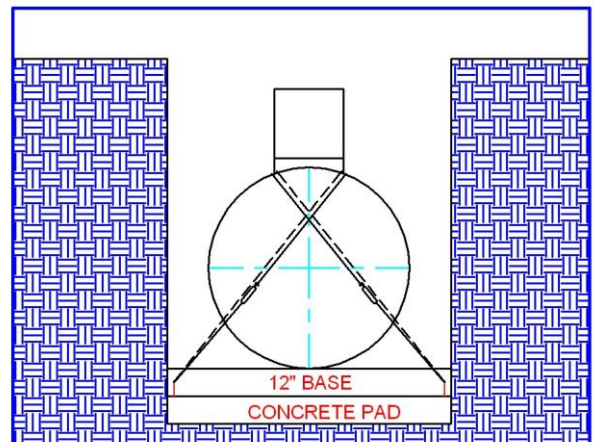

FIGURE 11-2

- Allow for sufficient depth in the excavation for at least 12 inches of approved Bedding Material between the base of the tank and the anchor slab.

### Hold-downs

- Only a FRP/Mocoat Fiberglass Ltd. Tie-Down Kit may be used when anchoring a FRP/Mocoat Fiberglass Ltd. tank.
- Using the long galvanized cable (25'L) loop around the deadmen, concrete pads, or steel tie-down rods.
- Use three (3) cable clamps and clamp the cable together.
- The saddle of the clamp must go over the live portion of the cable and not the dead end (never saddle a dead horse).

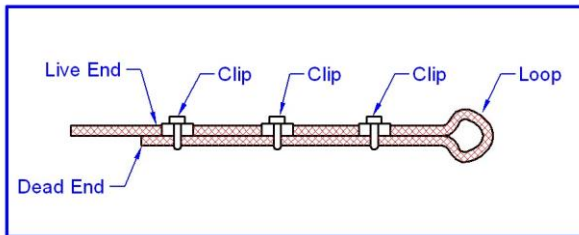

FIGURE 11-3

- With the free end of the long cable loop around the base of the collar and through the turnbuckle. Clamp the cable together as described earlier.
- Using the short cable (5'L) loop around the turnbuckle and around the deadmen, concrete pads, or steel tie-down rods. Clamp cable together as described above.
- Repeat the above steps for the other side of the Ball Tank.

- Each turnbuckle should then be hand tightened to a snug position and then tool tightened using the same number of turns on each turnbuckle to maintain a consistent tension on each cable.
- Evenly distribute loads by tightening all cables uniformly until they are snug without causing deflections in the tank.

### Tie-Down Kit Content

- 2 – Galvanized Aircraft Cables (5/16" diameter by 5 feet long)
- 2 – Galvanized Aircraft Cables (5/16" diameter by 25 feet long)
- 24 – Galvanized 5/16" Cable Clamps
- 2 – Galvanized Turnbuckles 1/2" by 6" (2600 pounds working strength)
- Tank anchor length should equal tank length.