

PLAN

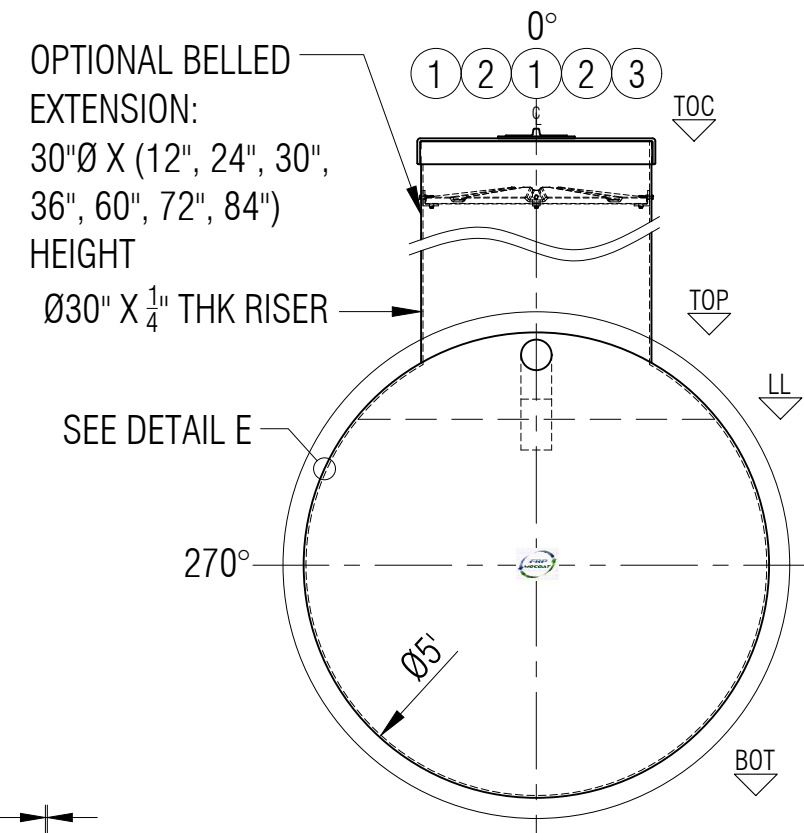

ELEVATION B

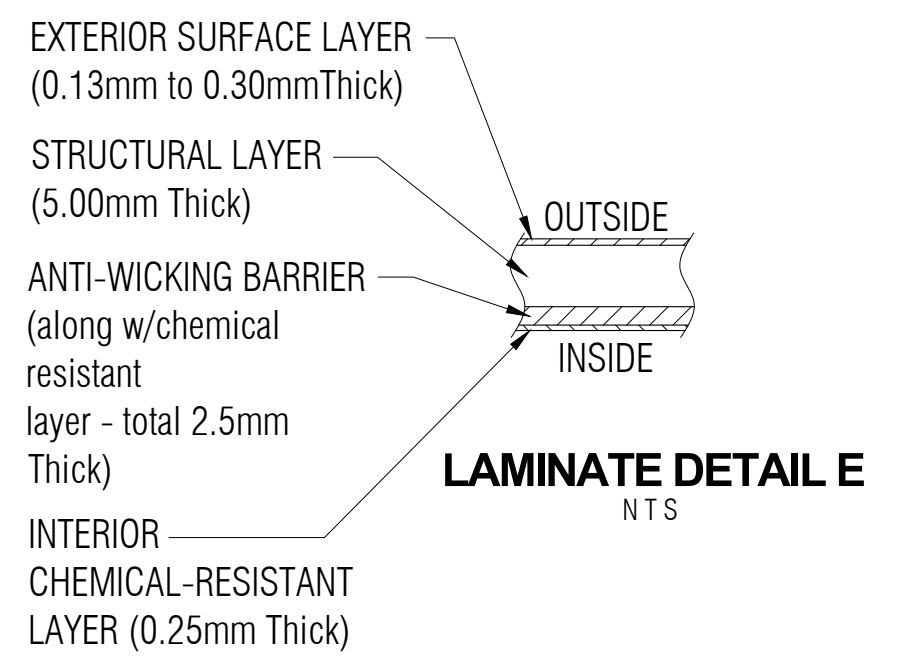

LAMINATE DETAIL E
NTS

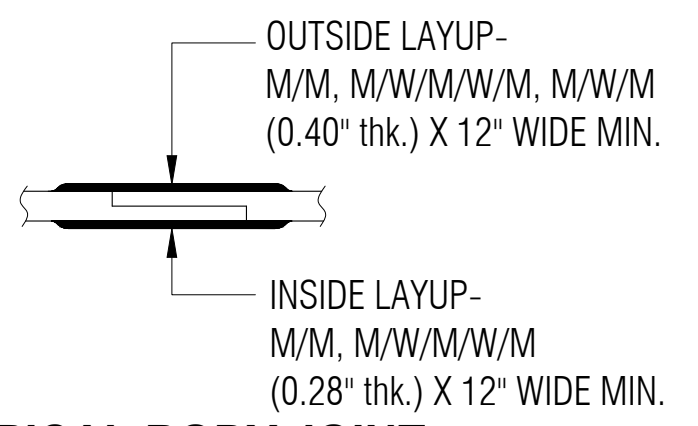

TYPICAL BODY JOINT DETAIL D
NTS

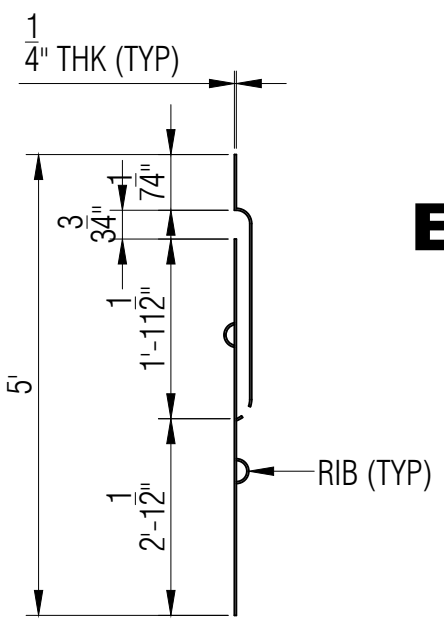

SIPHON/BAFFLE DETAIL H

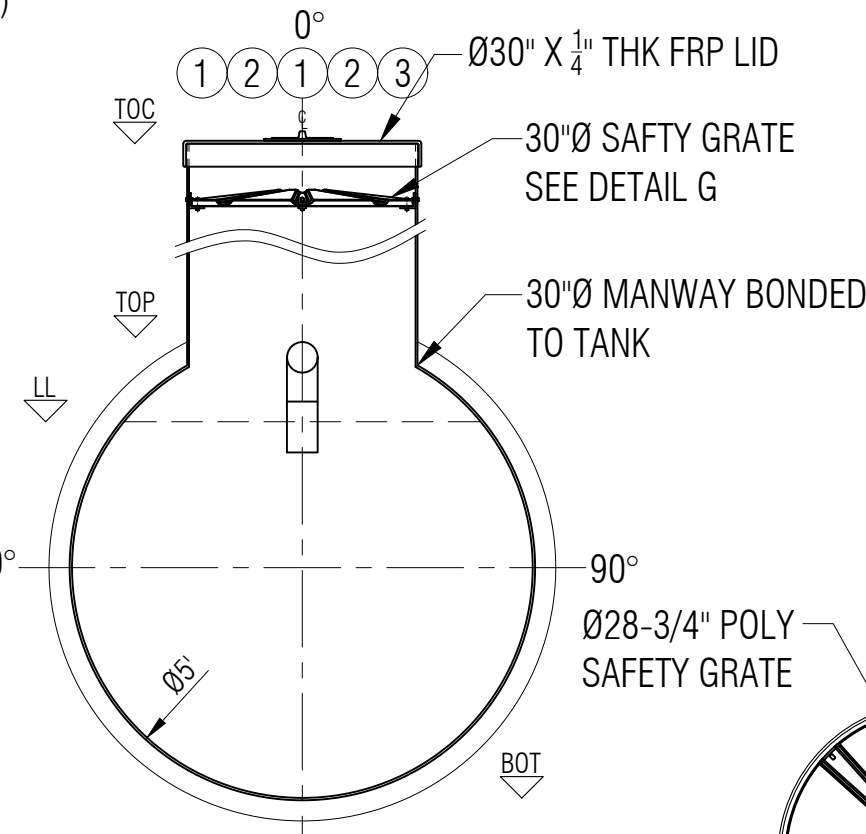

SECTION C

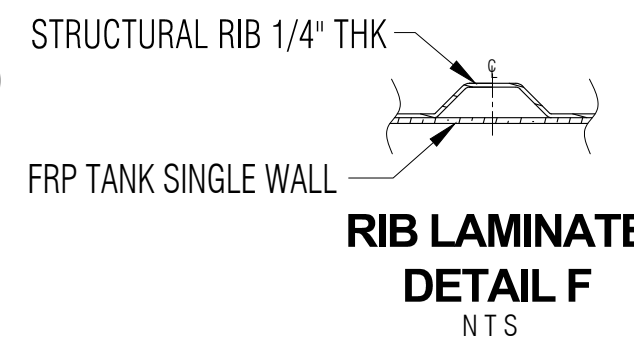

RIB LAMINATE DETAIL F
NTS

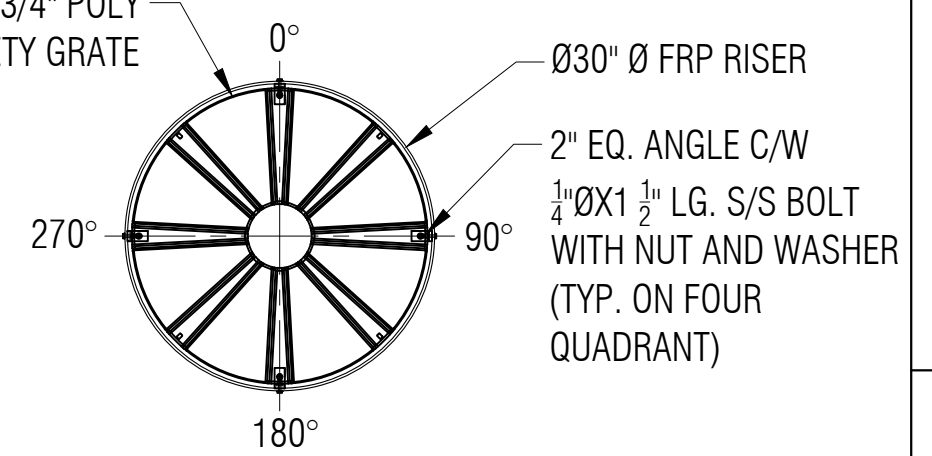

SAFETY GRATE DETAIL G
SCALE: 1:15

LEGEND:
 TOC - TOP OF CAP LID
 TOF - TOP OF FLANGE
 TOP - TOP CYLINDER
 BOT - BOTTOM CYLINDER
 I/S - INSIDE
 LL - LIQUID LEVEL
 O.A.H. - OVERALL HEIGHT
 O.A.L. - OVERALL LENGTH
 I/S - INSIDE
 O/S - OUTSIDE
 Ø - DIAMETER
 ° - DEGREE/S
 TYP - TYPICAL
 CL - CENTER LINE
 NTS - NOT TO SCALE

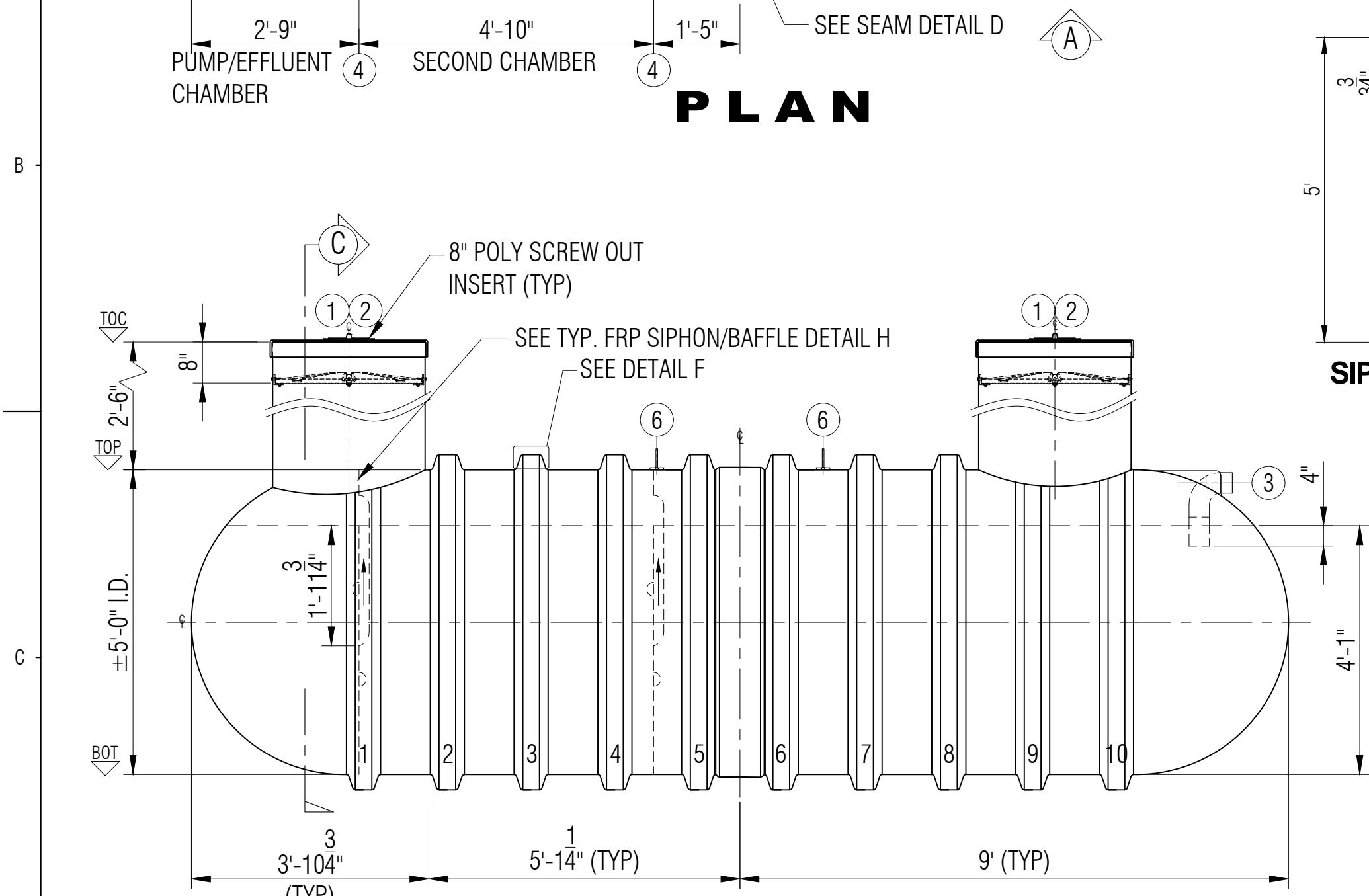

ELEVATION A

GENERAL NOTES:
 - CSA B66 CERTIFIED FRP SEPTIC TANK.
 - RATED FOR 7' OF BURIAL DEPTH AND NO TRAFFIC LOADING.
 - BAFFLE WALL IS INSTALLED. VOLUMES ARE APPROXIMATE.
 - ALL DRILLED HOLES FLANGES TO BE COATED WITH RESIN.
 - SAFETY DEVISE CAN WITHSTAND 91 KG. OF DEAD LOAD.
 - DIMENSIONS SHOWN IN FEET INCHES FORMAT OTHERWISE NOTED.
 - 1/2" FABRICATION TOLERANCE. DOES NOT APPLY TO LAMINATE THICKNESS.

ITEM#	QTY	PART LIST	DESCRIPTION	SHELL THICKNESS:	0.300"	DRAWN:	ATF
1	2	30" CAP LID W/ 8" D POLY SCREW OUT INSERT	FRP LID	DISH HEAD THICKNESS:	0.300"	CHECKED:	
2	2	30" Ø MANWAY COLLAR	30" Ø FRP MANWAY	RIBS THICKNESS:	0.25" WITH 1 WR	DATE:	JUNE 15, 2023
3	1	4" PVC-DWV 90°	INLET	WEIGHT:	635KG (1,400 LBS)	DESIGNED:	
4	2	FRP FULL BAFFLE WALL W/ REINFORCEMENT	BAFFLE WALL	LENGTH:	4,877MM (16'-0")	APPROVED:	MPS
5	1	POLYETHYLENE SAFETY GRATE C/W HARDWARE	SAFETY GRATE	FIRST CHAMBER:	4,695L (1,033IG/1,240 USG)	MFG:	DS
6	2	MILD STEEL	LIFT LUGS	SECOND CHAMBER:	2,350L (517IG/620 USG)	QA:	GA
7				EFFLUENT CHAMBER:	963L (212IG/254 USG)	SALES:	TA

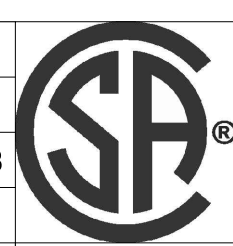

CLIENT: FRP/MOCOAT FIBERGLASS LTD.			
TITLE: 3CPO-1600 FRP PUMPOUT TANK			
FRP MOCOAT FIBERGLASS LTD.			
SIZE: C	DRAWING NUMBER: 3CPO-1600	REVISION: 0	
SCALE: 1:25	WEIGHT:	SHEET: 1/1	
BURIAL DEPTH:	RATED 7'-0"		