

**PLAN**

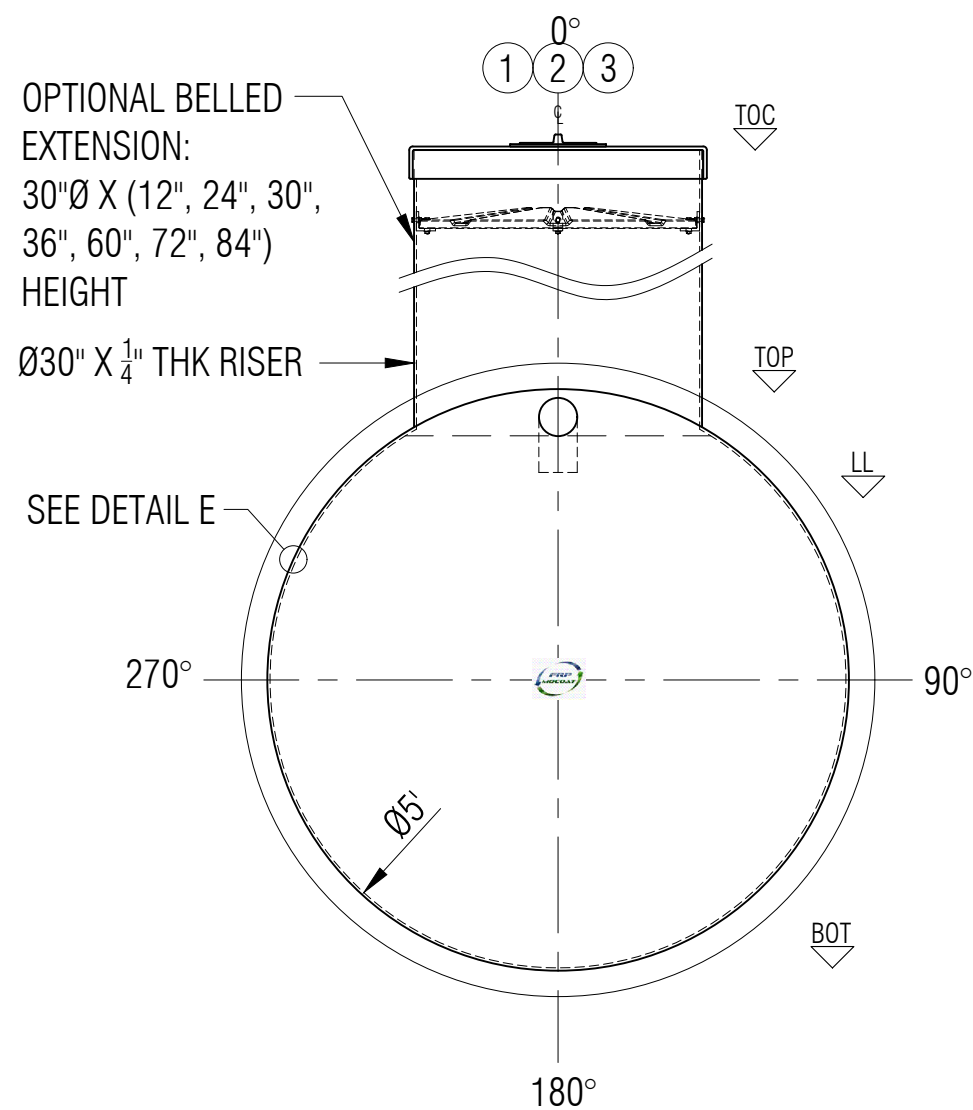

**ELEVATION B**

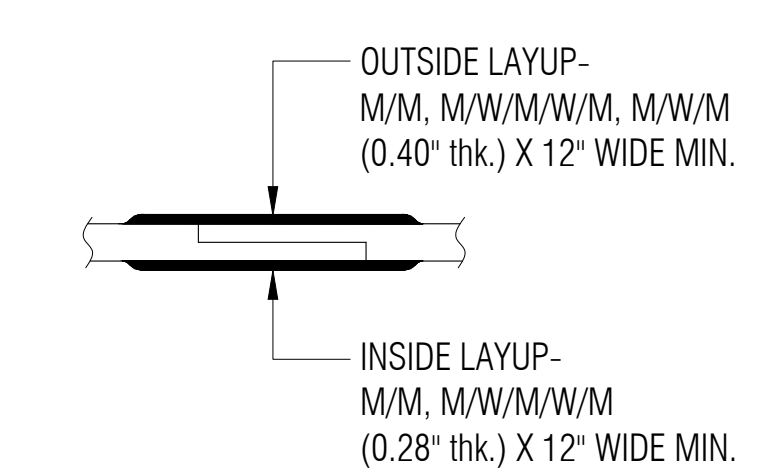

**TYPICAL BODY JOINT  
DETAIL D**  
NTS

LEGEND:  
 TOC - TOP OF CAP LID  
 TOF - TOP OF FLANGE  
 TOP - TOP CYLINDER  
 BOT - BOTTOM CYLINDER  
 I/S - INSIDE  
 LL - LIQUID LEVEL  
 O.A.H.-OVERALL HEIGHT  
 O.A.L.-OVERALL LENGTH  
 I/S - INSIDE  
 O/S - OUTSIDE  
 Ø - DIAMETER  
 ° - DEGREE/S  
 TYP- TYPICAL  
 CL - CENTER LINE  
 NTS - NOT TO SCALE

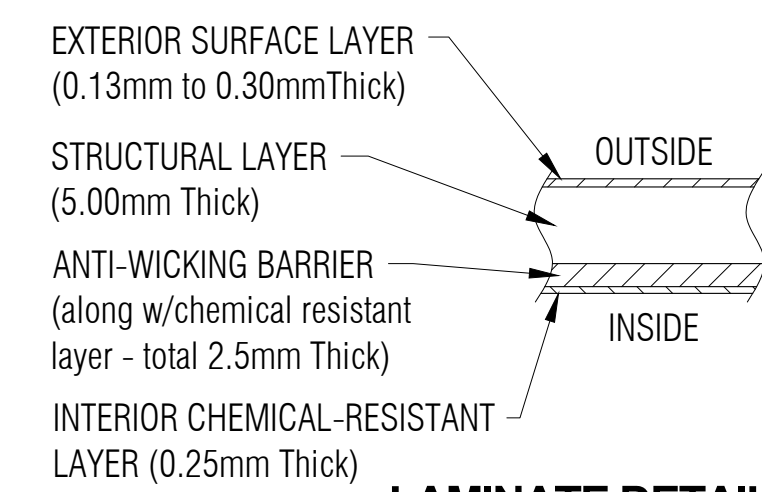

**LAMINATE DETAIL E**  
NTS

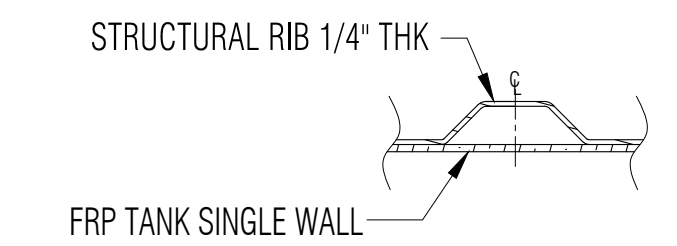

**RIB LAMINATE  
DETAIL F**  
NTS

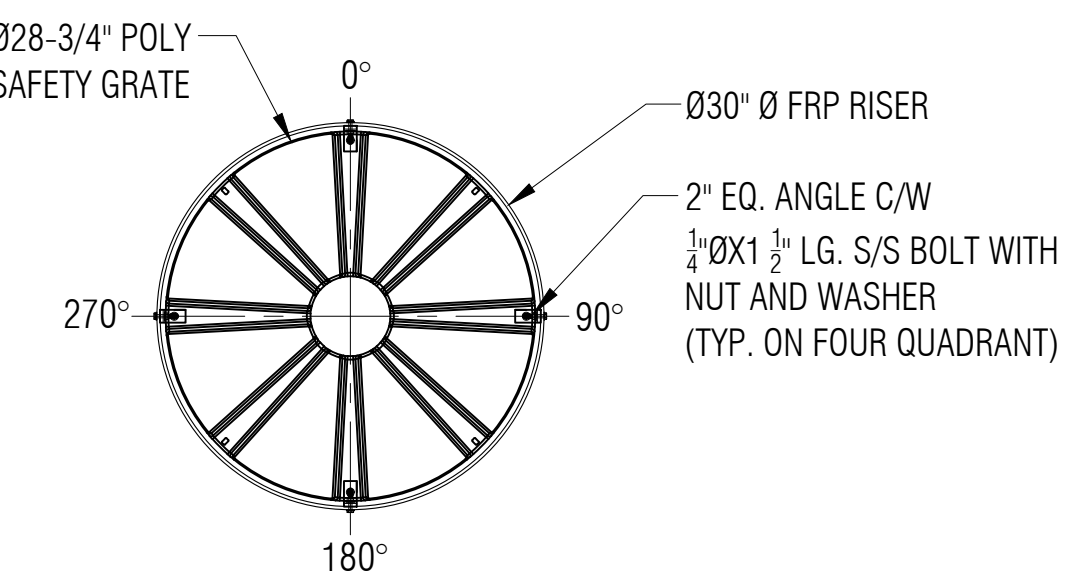

**SAFETY GRATE  
DETAIL G**  
SCALE: 1:15

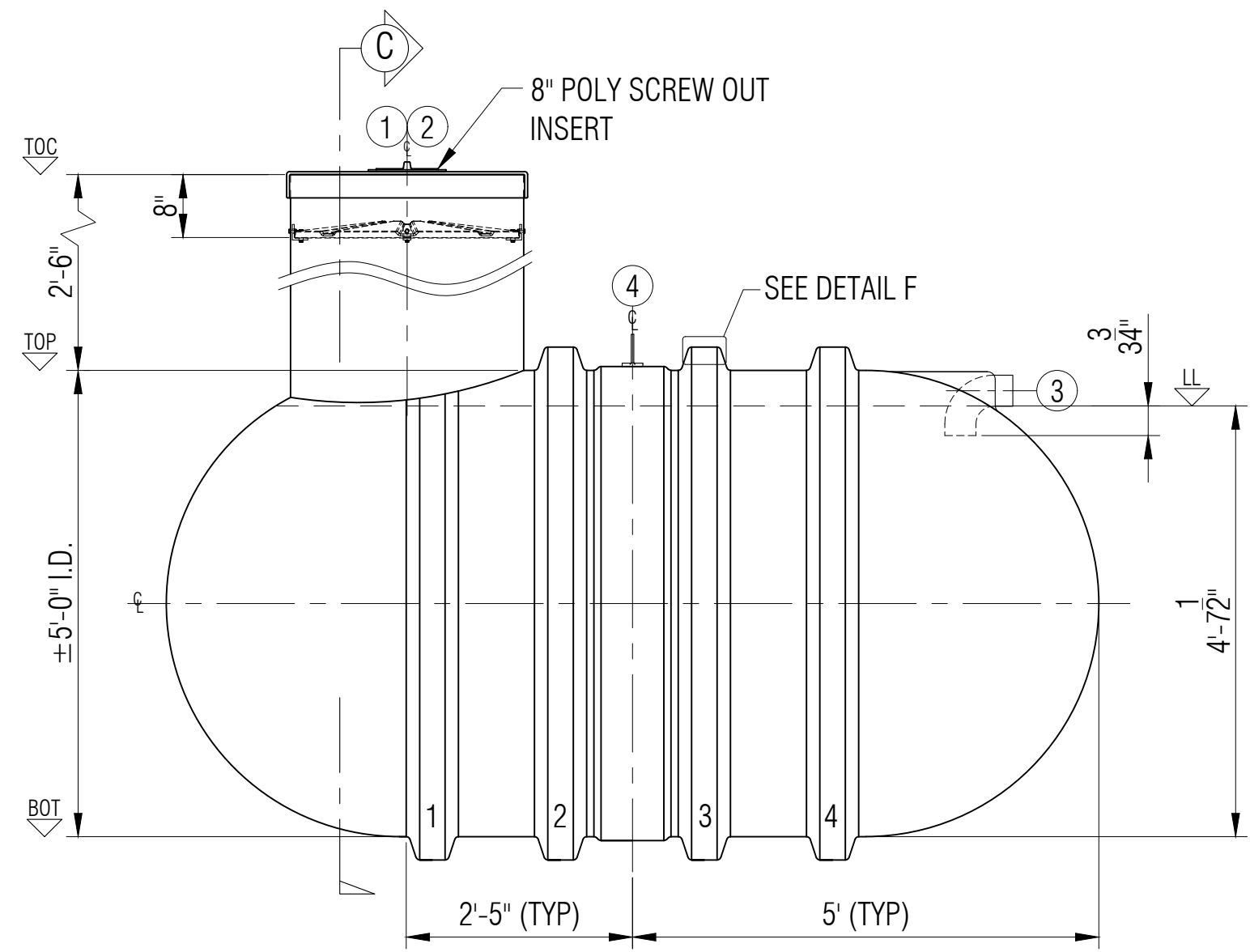

**ELEVATION A**

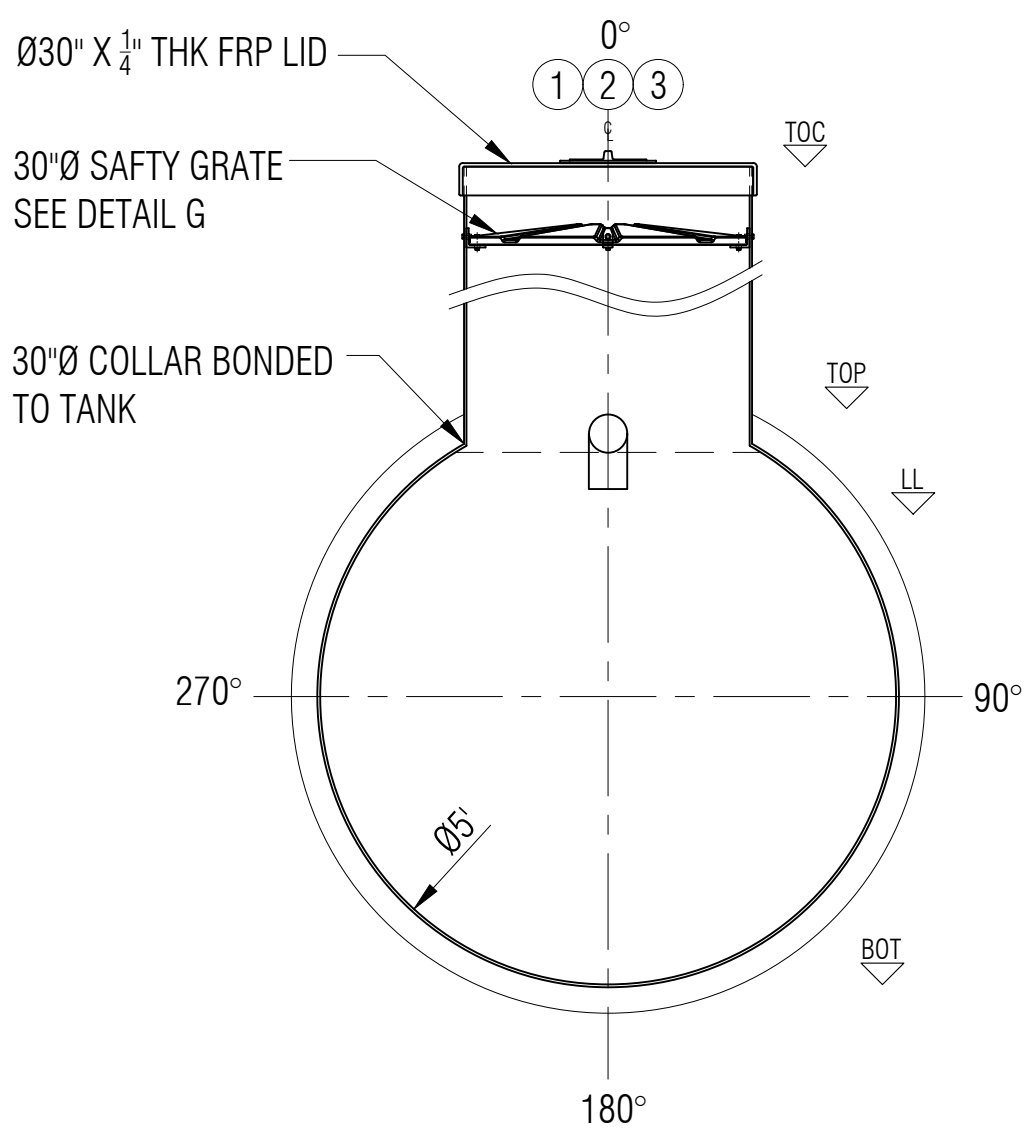

**SECTION C**

GENERAL NOTES:  
 - CSA B66 CERTIFIED FRP SEWAGE HOLDING TANK.  
 - RATED FOR 12' OF BURIAL DEPTH AND NO TRAFFIC LOADING.  
 - ALL DRILLED HOLES FLANGES TO BE COATED WITH RESIN.  
 - SAFETY DEVISE CAN WITHSTAND 91 KG. OF DEAD LOAD.  
 - DIMENSIONS SHOWN IN FEET INCHES FORMAT OTHERWISE NOTED.  
 - 1/2" FABRICATION TOLERANCE. DOES NOT APPLY TO LAMINATE THICKNESS.

ITEM#	QTY	PART LIST	DESCRIPTION	SHELL THICKNESS: 0.346"	DRAWN: ATF
1	1	30" CAP LID W/ 8" D POLY SCREW OUT INSERT	FPR LID	DOME HEAD THICKNESS: 0.351"	CHECKED:
2	1	30" Ø MANWAY COLLAR	30" Ø FRP MANWAY	RIBS THICKNESS: 0.30" WITH 1 WR	DATE: JUNE 08, 2023
3	1	4" PVC-DWV 90°	INLET	RIB SPACING: 16-1/2" CL TO CL	DESIGNED:
4	1	MID STEEL	LIFT LUG	WEIGHT: 283KG (625LBS)	APPROVED: MPS
5	1	POLYETHYLENE SAFETY GRATE C/W HARDWARE	SAFETY GRATE	LENGTH: 3,048MM (10'-0")	MFG: DS
6				WORKING CAPACITY: 4,434 L (975 IG/1,170 USG)	QA: GA
7				OVERALL CAPACITY: 4,546 L (1,000 IG/1,200 USG)	SALES: TA



CLIENT: FRP/MOCOAT FIBERGLASS LTD.		REVISION: 0	
TITLE: H1000-DB FRP SEWAGE HOLDING TANK		SHEET: 1/1	
SIZE: C	DRAWING NUMBER: H1000-DB	WEIGHT:	RATED 12'-0"
SCALE: 1:20	BURIAL DEPTH:		