

**PLAN**

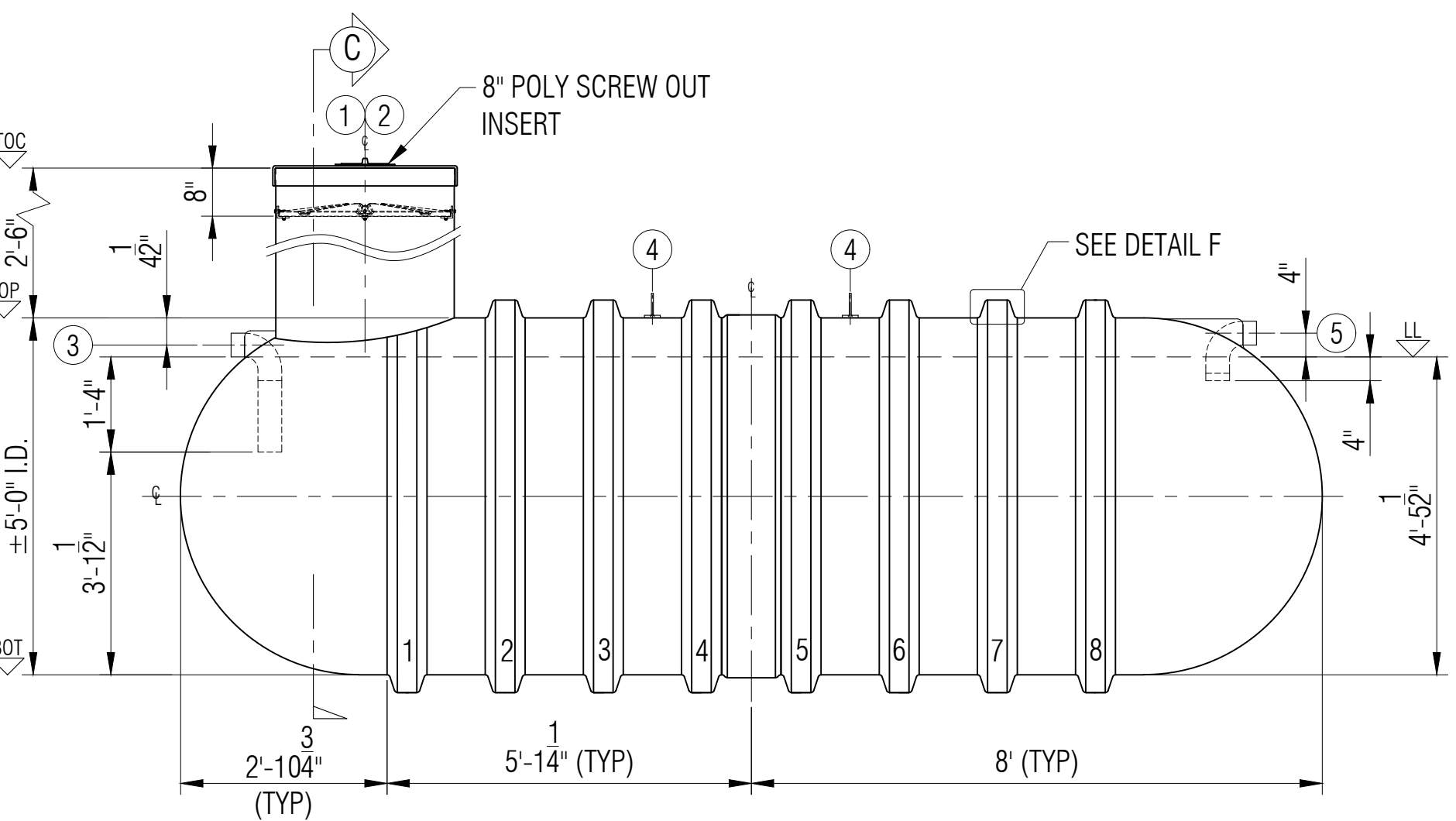

**ELEVATION A**

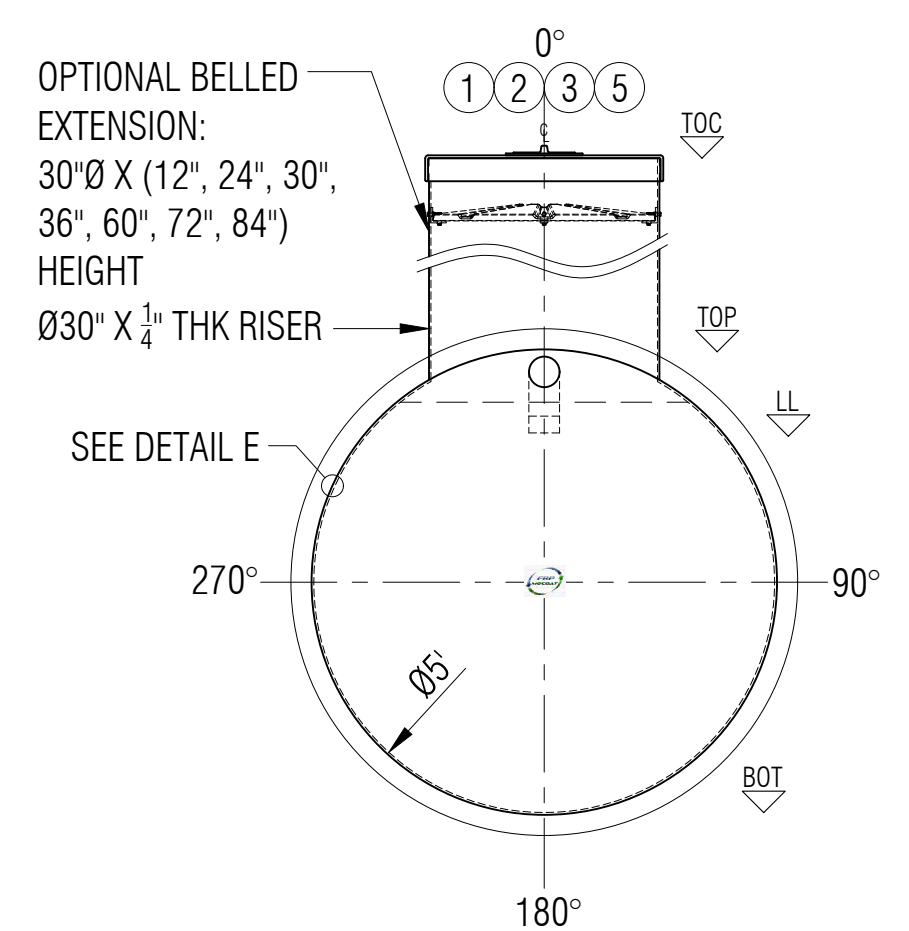

**ELEVATION B**

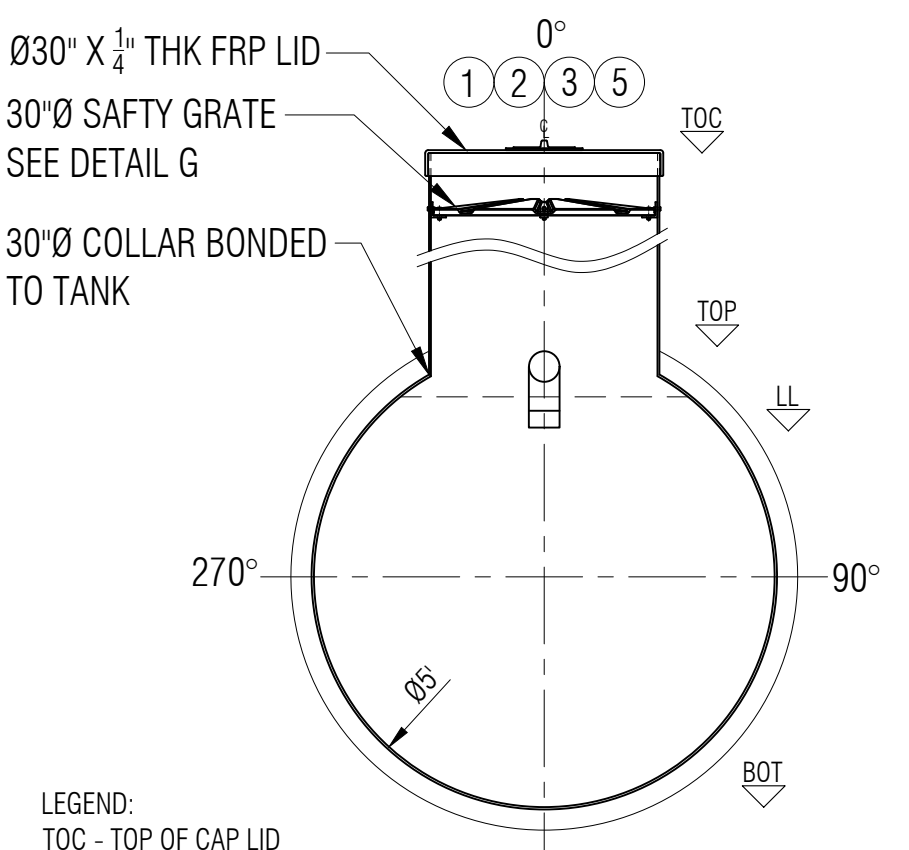

**SECTION C**

LEGEND:  
 TOC - TOP OF CAP LID  
 TOF - TOP OF FLANGE  
 TOP - TOP CYLINDER  
 BOT - BOTTOM CYLINDER  
 I/S - INSIDE  
 LL - LIQUID LEVEL  
 O.A.H.-OVERALL HEIGHT  
 O.A.L.-OVERALL LENGTH  
 I/S - INSIDE  
 O/S - OUTSIDE  
 Ø - DIAMETER  
 ° - DEGREE/S  
 TYP- TYPICAL  
 CL - CENTER LINE  
 NTS - NOT TO SCALE

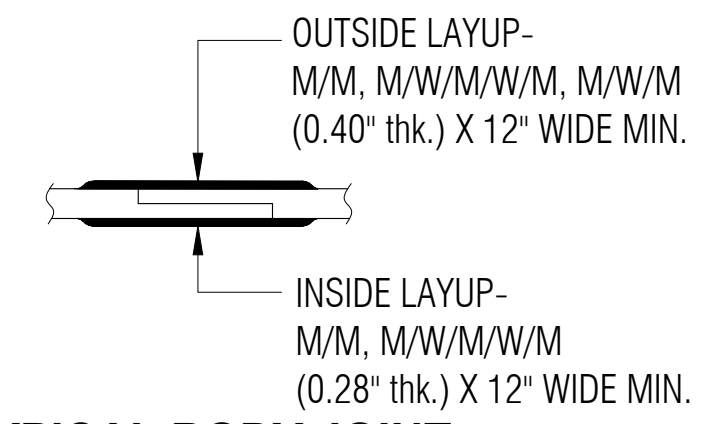

**TYPICAL BODY JOINT DETAIL D**  
NTS

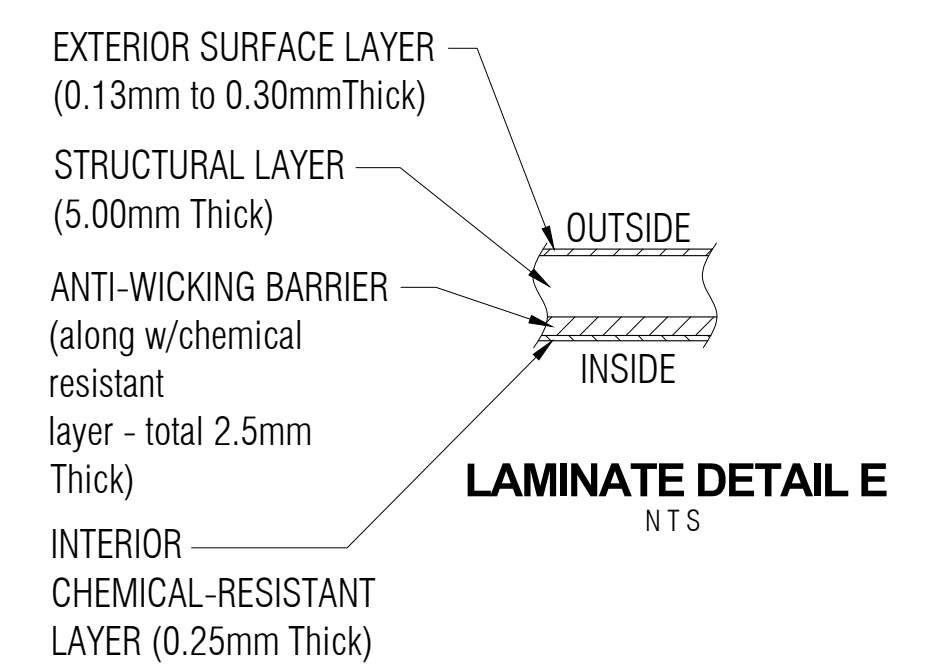

**LAMINATE DETAIL E**  
NTS

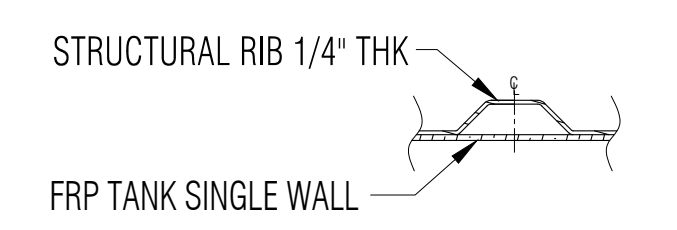

**RIB LAMINATE DETAIL F**  
NTS

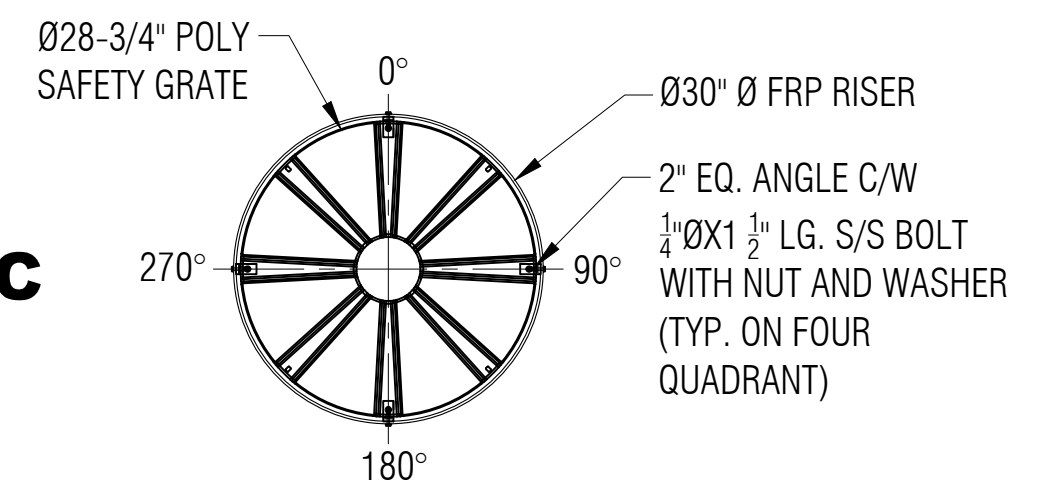

**SAFETY GRATE DETAIL G**  
SCALE: 1:15

GENERAL NOTES:  
 - CSA B66 CERTIFIED FRP SEWAGE HOLDING TANK.  
 - RATED FOR 7' OF BURIAL DEPTH AND NO TRAFFIC LOADING.  
 - ALL DRILLED HOLES FLANGES TO BE COATED WITH RESIN.  
 - SAFETY DEVICE CAN WITHSTAND 91 KG. OF DEAD LOAD.  
 - DIMENSIONS SHOWN IN FEET INCHES FORMAT OTHERWISE NOTED.  
 - 1/2" FABRICATION TOLERANCE. DOES NOT APPLY TO LAMINATE THICKNESS.

ITEM#	QTY	PART LIST	DESCRIPTION	SHELL THICKNESS: 0.300"	DRAWN: ATF
1	1	30" CAP LID W/ 8"Ø POLY SCREW OUT INSERT	FRP LID	DISH HEAD THICKNESS: 0.300"	CHECKED:
2	1	30"Ø MANWAY COLLAR	30"Ø FRP MANWAY	RIBS THICKNESS: 0.25" WITH 1 WR	DATE: JUNE 02, 2023
3	1	4" PVC-DWV 90°	OULET	RIB SPACING: 16-1/2" CL TO CL	DESIGNED:
4	2	MID STEEL	LIFT LUGS	WEIGHT: 397KG (875LBS)	APPROVED: MPS
5	1	4" PVC-DWV 90°	INLET	LENGTH: 4,877MM (16'-0")	MFG: DS
6	1	POLYETHYLENE SAFETY GRATE C/W HARDWARE	SAFETY GRATE	WORKING CAPACITY: 7,390 L (1,625 IG/1,950 USG)	QA: GA
7				OVERALL CAPACITY: 7,955 L (1,750 IG/2,100 USG)	SALES: TA



CLIENT: FRP/MOCOAT FIBERGLASS LTD.		REVISION: 0	
TITLE: <b>T1750 FRP TRICKLE TANK</b>		SHEET: 1/1	
FRP MOCOAT FIBERGLASS LTD.		SCALE: 1:25	
SIZE: C	DRAWING NUMBER: T1750	WEIGHT:	BURIAL DEPTH: RATED 7'-0"